



# Track-Dumper



**RD 620**



# Track-Dumper RD 620

## Technical Data

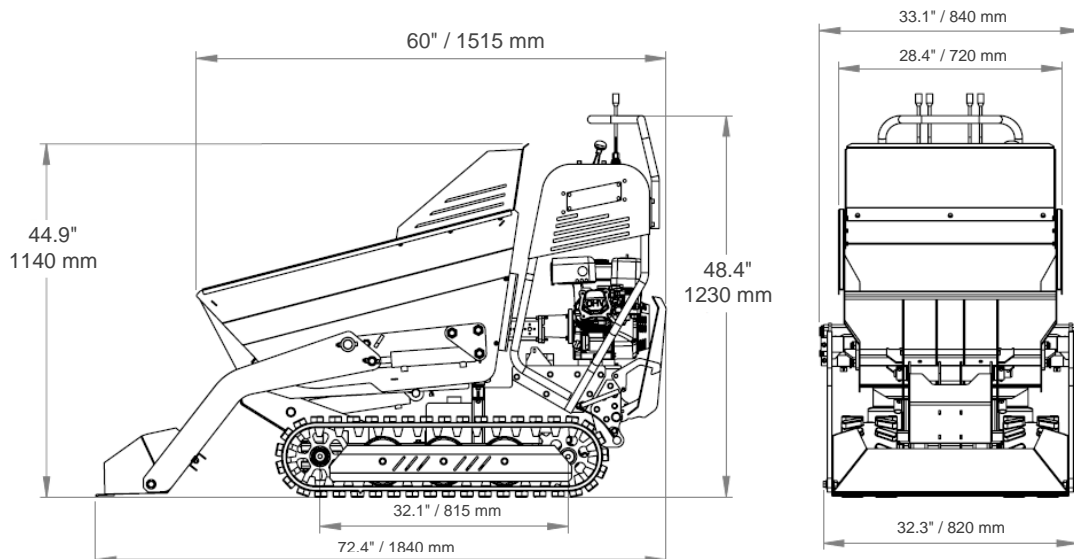

<b>Engine</b>	
Honda	GX 200
Type	1 cyl. / 4-stroke
Displacement	196 cm <sup>3</sup>
Engine Output	4.8 kW / 6.5 HP
Revolution Speed	3600/rpm
Starter	Reversing + Electric Starter
Air Filter	Oil Bath
Fuel Filter	Gauze



<b>Drive</b>	Hydrostatic
<b>Guidance</b>	Hydraulic motor
<b>Characteristic</b>	Hydraulic tipping device Hydraulic self loader Electric start
<b>Optional Accessories</b>	Snow blade



<b>Operating data</b>		
Weight	385 kg	849 lbs.
Max. Payload	620 kg	1367 lbs.
Max. Weight (loaded)	1005 kg	2216 lbs.
Tipping Device	Hydraulic	Hydraulic
Climbing Ability	Max. 26° (50%)	Max. 26° (50%)
Working Speed	0 - 4 km/h	0 - 2.5 mph
Oil Pressure	180 bar	2,610 psi
Flow Rate	12.6 ltr./min.	3.3 gal/min
Dumper Box Volume	280 ltr.	0.37 cu. yard

Authorized dealer:

National Distributor of PowerPac Equipment:



[www.pmiequipment.com](http://www.pmiequipment.com)