



Multi-Loader

ML 300N



**Multi-Loader
ML 300N**

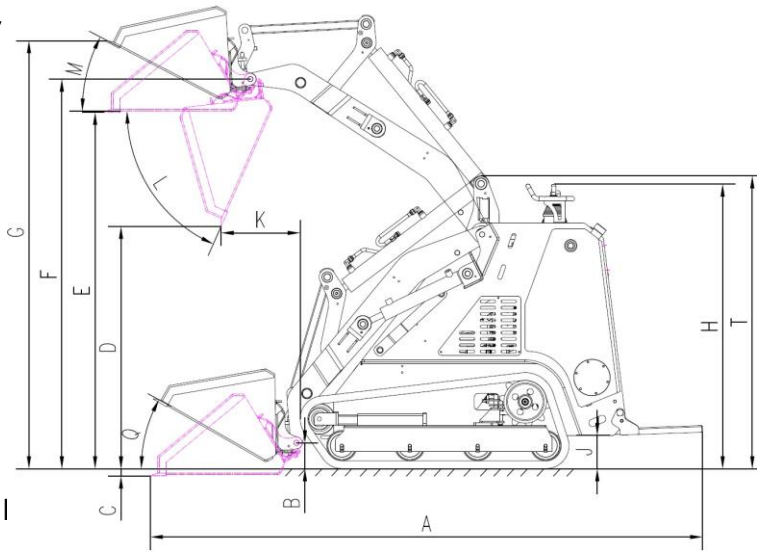

	mm	inches
A	2651	104.37
B	124	4.88
C	35	1.38
D	1162	45.75
E	1708	67.24
F	1867	73.50
G	2052	80.79
H	1364	53.70
J	160	6.30
K	380	14.96
L	66°	66°
M	28°	28°
N	900	35.43
O	970	38.19
T	1404	55.28
Q	29°	29°

Technical I

Motor		
Honda	GX 690	
Type	2 Cyl. / 4-stroke	
Displacement	688 cm ³	
Engine Output	18.4 kW / 25.0 HP	
Revolution Speed	3600 rpm	
Starter	Electric Starter	
Air Filter	Dry Cartridge	
Fuel Filter	Sieve	
Drive	Hydrostatic	
Guidance	Hydraulic motor	
Multi-Valve block	Hydrocontrol - Italy	
Hydraulic pump	Permco - USA	
Characteristic	Quick-change system joystick control, electric start	
Operating Data		
Weight Without Attachments	1050 kg	2315 lbs
Operating Payload	300 kg	660 lbs
Operating Weight (loaded)	1350 kg	2976 lbs
Tipping Device	Hydraulic	Hydraulic
Climbing Ability	Max. 20° (36%)	Max. 20° (36%)
Working Speed	0 – 5 km/h	0 - 3.1 mph
Oil Pressure	180 bar	2611 psi
Oil Flow Rate	24.6 ltr./min.	6.5 gal./min
Accessories	4 in 1 bucket, excavator, pallet fork, gripper, auger, sweeper, trencher, hydraulic breaker/hammer, gripper (croc)	



Authorized Dealer:

National Distributor of PowerPac Equipment:



www.pmiequipment.com